

# SPADA-ML<sup>®</sup>

## FREEFLOAT HANDGUARD

### INSTALLATION INSTRUCTIONS

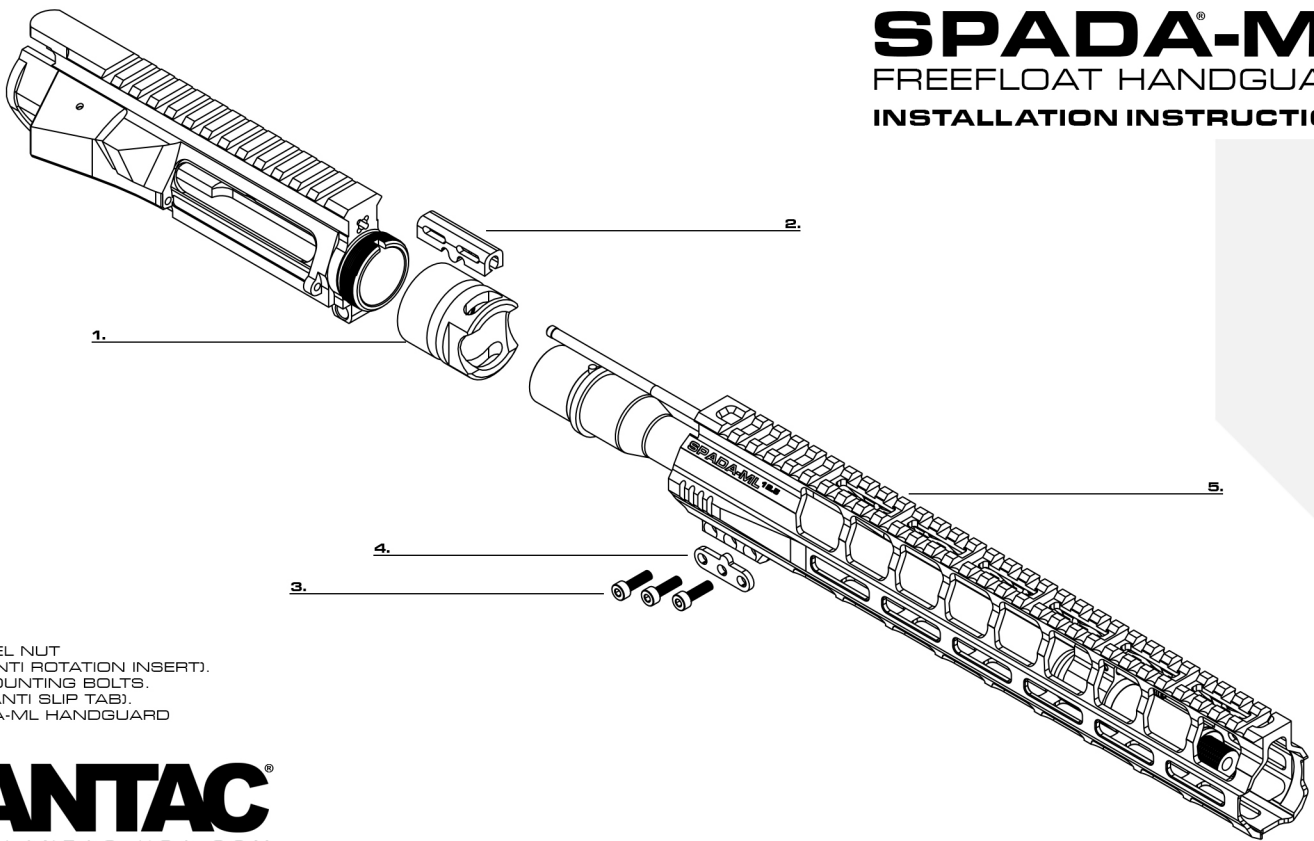

#### KEY

1. BARREL NUT
2. ARI (ANTI ROTATION INSERT).
3. X3 MOUNTING BOLTS.
4. AST (ANTI SLIP TAB).
5. SPADA-ML HANDGUARD

# LANTAC<sup>®</sup>

WWW.LANTAC-USA.COM

SHOWN WITH OPTIONAL LANTAC UAR RECEIVER, GB-750S GAS BLOCK, GAS TUBE & BARREL NOT INCLUDED. FOR ILLUSTRATIVE PURPOSES ONLY. NOTE: IT MAY BE NECESSARY TO SHORTEN THE EJECTION PORT RETAINING ROD IN ORDER TO FIT THE HANDGUARD.

#### WARNING.

IF YOU ARE UNSURE OF ANY OF THE STEPS INVOLVED DURING INSTALLATION OF THIS FREEFLOAT HANDGUARD, PLEASE HAVE A QUALIFIED ARMORER/ GUNSMITH UNDERTAKE THE WORK. LANTAC USA LLC CANNOT BE HELD RESPONSIBLE FOR DAMAGE OR INJURY SUSTAINED THROUGH IMPROPER INSTALLATION OF THIS PRODUCT.

**CHECK THAT THE FIREARM IS UNLOADED, REMOVE THE MAGAZINE AND CHECK THAT THE CHAMBER IS EMPTY. FAILURE TO DO SO MAY RESULT IN INJURY OR DEATH.**

THE SPADA-ML HANDGUARD REQUIRES THE USE OF A LOW PROFILE GAS BLOCK AND HAS BEEN DESIGNED TO WORK PERFECTLY WITH THE LANTAC GB750-S (SOLD SEPERATELY). OTHER LARGER SIZED GAS BLOCKS WILL NOT FIT UNDER THE HANDGUARD AND CANNOT BE USED.

INSTALLATION OF THE SPADA-ML WILL ALSO REQUIRE THE REMOVAL OF THE STANDARD BARREL NUT AND DELTA RING ASSEMBLY IF PRESENT.

THE FOLLOWING TOOLS WILL BE REQUIRED.

1. A TORQUE WRENCH CAPABLE OF 75 Ft/Lb
2. A 1-1/8" CROWFOOT WRENCH WITH SUITABLY SIZED DRIVE HOLE FOR THE TORQUE WRENCH.
3. A 9/64 SIZED ALLEN KEY FOR TIGHTENING THE CLAMPING BOLTS.
4. A HIGH QUALITY GREASE, WE RECOMMEND AEROSHELL 33MS. MIL-G-21164D

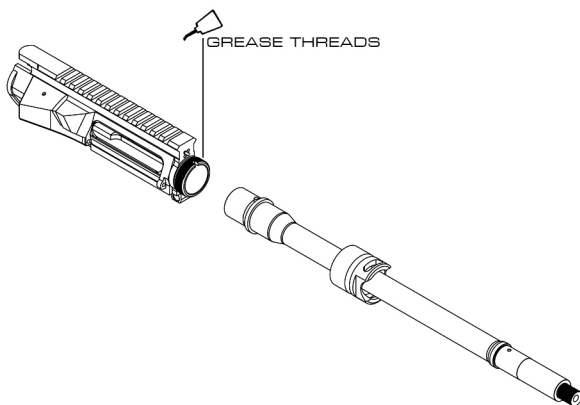

#### STEP1

PLACE THE UPPER RECEIVER IN A VICE BLOCK OR USE A VICE BAR AND MAKE SURE IT IS SECURELY HELD SO THAT IT CANNOT SLIP AND BECOME DAMAGED DURING THE INSTALLATION PROCEDURE.

CLEAN THE RECEIVER THREADS THOROUGHLY AND APPLY AEROSHELL 33MS GREASE PRIOR TO FITTING THE BARREL NUT (1.)

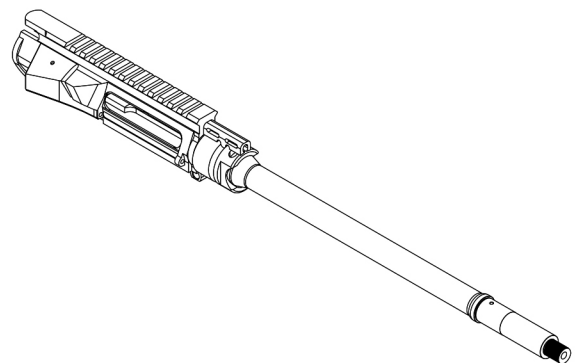

#### STEP2

INSERT THE BARREL INTO THE RECEIVER AND SCREW ON THE BARREL NUT (1.) BY HAND UNTIL TIGHT. SET A TORQUE WRENCH TO 35 Ft/LB AND TIGHTEN AND UNTIGHTEN THE BARREL NUT A TOTAL OF 3 TIMES TO PRE-SET THE THREADS. NOW SET THE TORQUE WRENCH TO 70-75 Ft/Lb AND TORQUE THE NUT TO ITS FINAL SETTING.

REST THE ANTI ROTATION INSERT (2.) ON TOP OF THE BARREL NUT MAKING SURE THAT THE LOWER LUG REGISTERS WITH THE GROOVE ON THE NUT, THE LONGER SECTION SHOULD ALSO BE FACING THE RECEIVER.



PATENTED 9303941, 9528793 & 9513083

LANTAC USA LLC : FORUM WAY SOUTH : SUITE B : FORT WORTH : TEXAS : 76140. TEL: 817 420 6011.

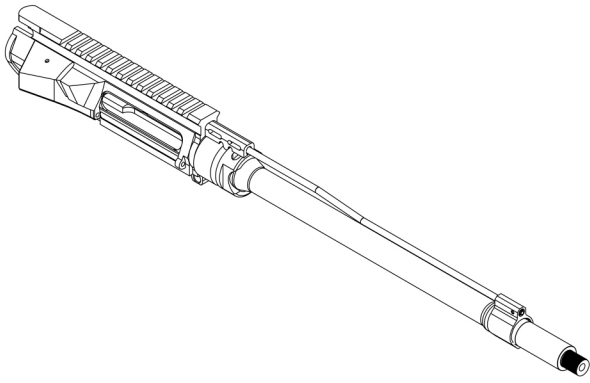

**STEP3**

INSTALL THE GAS TUBE AND GAS BLOCK. SLIDE THE GAS TUBE THROUGH THE ANTI ROTATION INSERT (2.) AND INTO THE UPPER RECEIVER. FIX THE GAS BLOCK AS INSTRUCTED BY THE RELEVANT MANUFACTURER. CHECK TUBE ALIGNMENT BEFORE AND AFTER TIGHTENING THE RETAINING SCREWS. WE RECOMMEND THE USE OF THE GB760-S SOLD SEPERATELY.

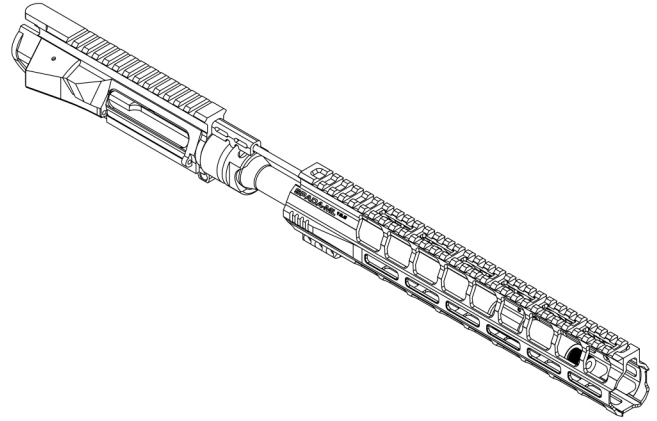

**STEP4**

MAKE SURE ALL CLAMPING BOLTS (3.) AND THE ANTI SLIP TAB (4.) ARE REMOVED FROM THE HANDGUARD (5.) AND CAREFULLY SLIDE IT OVER THE BARREL AND GAS BLOCK/ TUBE ASSEMBLY, ONTO AND OVER THE BARREL NUT (1.). REGISTER THE ANTI ROTATION INSERT (2.) WITH THE HANDGUARD (5.) SO THAT IT SLIDES INSIDE AS THE ASSEMBLY COMES TOGETHER.

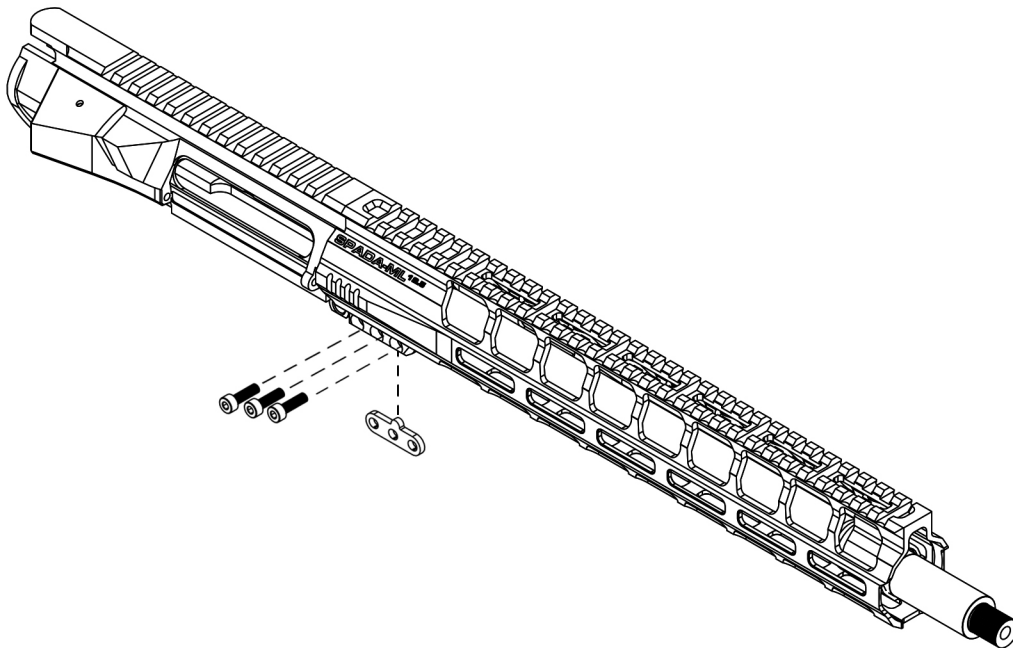

**STEP5**

WITH THE HANDGUARD (5.) IN PLACE INSERT THE ANTI SLIP TAB (4.) BETWEEN THE TWO CLAMPING FLANGES, MAKING SURE THAT THE TOP LUG REGISTERS WITH THE NOTCH IN THE BARREL NUT (1.)

INSERT THE 3 CLAMPING BOLTS (3.) AND TIGHTEN UNTIL THE HANDGUARD (5.) CLAMPS TO THE BARREL NUT (1.) TIGHTLY. THERE IS NO TORQUE SETTING FOR THESE BOLTS, HOWEVER DO NOT USE EXTREME FORCE OR THE THREADS MAY BE DAMAGED. THE MATING SURFACES OF THE HANDGUARD AND BARREL NUT OFFER A VERY EFFICIENT FIT. CLAMPING PRESSURE IS VERY HIGH WITHOUT REQUIRING EXCESSIVE FORCE ON THE BOLTS.

CHECK FINAL ALIGNMENT OF THE HANDGUARD TO THE UPPER RECEIVER AS THE BOLTS ARE TIGHTENED.



PATENTED 9303941, 9528793 & 9513083

LANTAC USA LLC : FORUM WAY SOUTH : SUITE B : FORT WORTH : TEXAS : 76140. TEL: 817 420 6011.